

Silicon NPN Power Transistors

2N4864

DESCRIPTION

- With TO-66 package
- Continuous collector current- $I_C=2A$
- High $V_{CEO}:120V$ (Min)

APPLICATIONS

- For use in general-purpose switching and linear amplifier applications

PINNING (See Fig.2)

PIN	DESCRIPTION
1	Base
2	Emitter
3	Collector

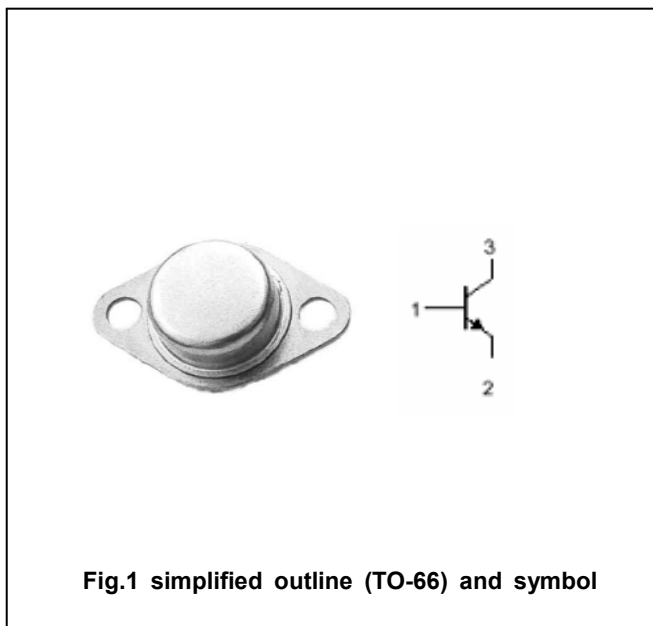

Fig.1 simplified outline (TO-66) and symbol

ABSOLUTE MAXIMUM RATINGS($T_a=25^\circ C$)

SYMBOL	PARAMETER	CONDITIONS	VALUE	UNIT
V_{CBO}	Collector-base voltage	Open emitter	140	V
V_{CEO}	Collector-emitter voltage	Open base	120	V
V_{EBO}	Emitter-base voltage	Open collector	7	V
I_C	Collector current		2	A
P_T	Total power dissipation	$T_C=25^\circ C$	16	W
T_j	Junction temperature		150	$^\circ C$
T_{stg}	Storage temperature		-65~200	$^\circ C$

THERMAL CHARACTERISTICS

SYMBOL	PARAMETER	MAX	UNIT
$R_{(th)jc}$	Thermal resistance junction to case	7.0	$^\circ C/W$

Silicon NPN Power Transistors

2N4864

CHARACTERISTICS

T_j=25°C unless otherwise specified

SYMBOL	PARAMETER	CONDITIONS	MIN	TYP.	MAX	UNIT
V _{CEQ(SUS)}	Collector-emitter sustaining voltage	I _C =0.1 A ; I _B =0	120			V
V _{CE(sat)}	Collector-emitter saturation voltage	I _C =2A; I _B =0.4A			1.5	V
V _{BE(sat)}	Base-emitter saturation voltage	I _C =2A; I _B =0.4A			2.0	V
V _{BE(on)}	Base -emitter on voltage	I _C =0.5A ; V _{CE} =5V			1.5	V
I _{CEX}	Collector cut-off current	V _{CE} =140V; V _{BE(off)} =1.5V T _C =150°C			2.0 5.0	mA
I _{CEO}	Collector cut-off current	V _{CE} =120V; I _B =0			10	mA
I _{EBO}	Emitter cut-off current	V _{EB} =7V; I _C =0			1.0	mA
h _{FE-1}	DC current gain	I _C =0.5A ; V _{CE} =5V	50		150	
h _{FE-2}	DC current gain	I _C =2A ; V _{CE} =5V	10			
C _{OB}	Output capacitance	I _E =0 ; V _{CB} =10V; f=1MHz		50		pF
f _T	Transition frequency	I _C =0.5A ; V _{CE} =5V		50		MHz

PACKAGE OUTLINE

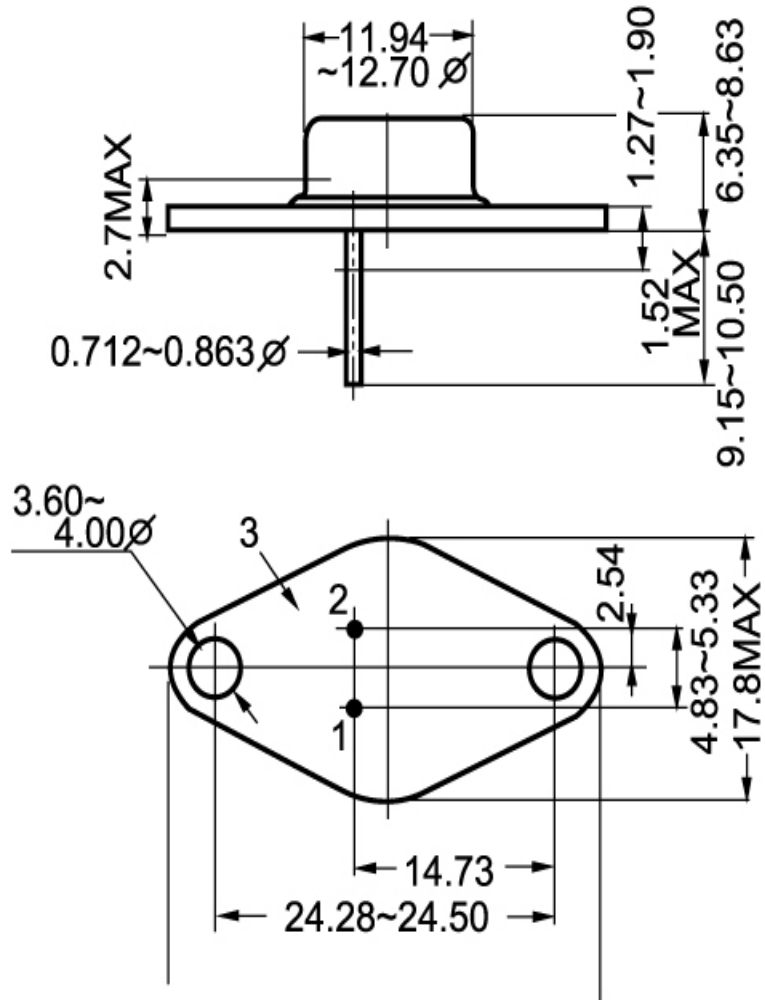

Fig.2 Outline dimensions